



Manual 1.0

Next-Level Audio Controller with
Class-Leading Sonic Performance



Contents

IMPORTANT SAFETY INSTRUCTIONS.....	5
COMPLIANCE.....	7
FOR CUSTOMERS IN EUROPE.....	7
FOR CUSTOMERS IN THE USA.....	7
DECLARATION OF CONFORMITY WITH FCC RULES.....	7
FEDERAL COMMUNICATIONS COMMISSION NOTICE.....	7
FOR CUSTOMERS IN CANADA.....	8
Thanks and Unpacking.....	9
Unpacking the NOVA HDC48 series controller.....	9
INSTALLATION INSTRUCTIONS.....	10
The User Guide.....	11
Introduction and Key Features.....	12
Introduction.....	12
Key Features.....	12
Audio Connections.....	14
Input Connections.....	14
Output Connections.....	14
Using unbalanced connections.....	15
Panel Layouts.....	16
Operation.....	18
Starting up the unit.....	18
Overview of Modules, Presets Components and Snapshots.....	18
Drive Modules.....	19
Drive Module Presets.....	20
Navigation and Designing Crossovers.....	21
Factory Module Presets.....	21
Storing Module Presets.....	22
Recalling Module Presets.....	22
Recalling Components.....	22
Input.....	23
AES3 / Network Inputs.....	23

Automatic Input Selection (Fallover)	24
Gain and Polarity.....	24
Delay	24
High Pass Filter	24
Parametric Equalisation	24
FIR Shelving EQ.....	24
Parametric Filters.....	25
Routing.....	25
Output.....	25
AES3 outputs.....	25
Gain and Polarity.....	25
Delay	25
High and Low pass Filters.....	26
LIR Crossover Filtering.....	26
Parametric Equalisation and All-Pass Filters.....	26
Limiters.....	27
Amplifier Gain	28
Routing.....	28
AES3	28
Utility Pages	28
Screen Contrast.....	28
Stereo Linking.....	28
Current Ethernet IP Address	29
IP Mode	29
IP Static.....	29
Store Snapshot.....	29
Recall Snapshot	29
Bandwidth Units.....	29
Aux Style.....	29
Ethernet	29
Ethernet configurations	29
DHCP	29
AUTO-IP	30
Static-IP	30

IP Troubleshooting.....	30
Snapshots.....	30
AUX Port.....	31
Latency delay	33
Input/Output Latencies.....	33
Processing Latencies	33
Secure Mode.....	34
Overlay Flush.....	34
Revert to Factory Settings.....	34
Processing Block Diagram	35
Input Menu Map Utility Menu Map.....	36
Output Menu Map	37
EQ and Filter Response Graphs.....	38
Technical Specifications	41
Connectors.....	41
Environmental.....	41
Dimensions.....	41
Options.....	42

IMPORTANT SAFETY INSTRUCTIONS



CAUTION

RISK OF ELECTRIC SHOCK
DO NOT OPEN

DO NOT EXPOSE TO
RAIN OR MOISTURE

ATTENTION

RISQUE DE CHOC ELECTRIQUE
NE PAS ENLEVER

NE PAS EXPOSER A LA
PLUIE NI A L'HUMIDITE



- 1 Read these instructions.
- 2 Keep these instructions.
- 3 Heed all warnings.
- 4 Follow all instructions.
- 5 Do not use this apparatus near water.
- 6 Clean only with dry cloth.
- 7 Do not block any ventilation openings. Install in accordance with the manufacturer's instructions.
- 8 Do not install near any heat sources such as radiators, heat registers, stoves or other apparatus (including amplifiers) that produce heat.
- 9 Do not defeat the safety purpose of the polarized or grounding type plug. A polarized plug has two blades with one wider than the other. A grounding type plug has two blades and a third grounding prong. The wide blade or the third prong are provided for your safety. If the provided plug does not fit into your outlet, consult an electrician for replacement of the obsolete outlet.
- 10 Protect the power cord from being walked on or pinched particularly at plugs, convenience receptacles and the point where they exit from the apparatus.
- 11 Only use attachments / accessories specified by the manufacturer.
- 12 Use only with the cart, tripod, bracket or table specified by the manufacturer, or sold with the apparatus. When a cart is used, use caution when moving the cart / apparatus combination to avoid injury from tip-over.
- 13 Unplug this apparatus during lightning storms or when unused for long periods of time.
- 14 Refer all servicing to qualified service personnel. Service is required when the apparatus has been damaged in any way, such as power-supply cord or plug damaged, liquid has been spilled or objects have fallen into the apparatus, this apparatus has been exposed to rain or moisture, does not operate normally, or has been dropped.

SAFETY WARNING

Permanent disconnection from the mains supply is to be achieved by removing the supplied cord connector from the back of the unit.

SAFETY WARNING

Do not remove any covers, loosen any fixings or allow items to enter any aperture.

SAFETY WARNING

Objects filled with liquids should not be placed on this apparatus.

SAFETY WARNING

Replace the mains fuse only with a fuse of the same type

SAFETY WARNING

The rear of the product may get hot. Avoid direct skin contact during operation and for at least 5 minutes after power has been isolated.

AVERTISSEMENT DE SECURITE

Pour déconnecter l'appareil de l'alimentation principale de façon permanente, débranchez le connecteur du câble fourni à l'arrière de l'appareil.

AVERTISSEMENT DE SECURITE

Ne retirez pas les couvercles, ne desserrez pas les fixations et ne laissez aucune pièce s'introduire dans les ouvertures.

AVERTISSEMENT DE SECURITE

Ne placez pas d'objets contenant du liquide à proximité de l'appareil.

AVERTISSEMENT DE SECURITE

Ne remplacez le fusible de réseau principal que par un fusible du même type.

AVERTISSEMENT DE SECURITE

Le radiateur arrière de cet appareil devient chaud. Evitez tout contact direct avec la peau pendant le fonctionnement et au moins 5 minutes après la mise hors tension de l'appareil.

COMPLIANCE

FOR CUSTOMERS IN EUROPE

This product complies with both the LVD (electrical safety) 73/23/EEC and EMC (electromagnetic compatibility) 89/336/EEC directives issued by the Commission of the European Community.

Compliance with these directives implies conformity with the following European standards:

EN60065 Product safety

EN55103-1 EMC emissions

EN55103-2 EMC immunity

This product is intended for the following electromagnetic environments: E1, E2; E3 & E4.

FOR CUSTOMERS IN THE USA

This product has been tested for electrical safety and complies with:

UL60065 7th edition

DECLARATION OF CONFORMITY WITH FCC RULES

We, CRAFT AUDIO GmbH, Gewerbering 42, 94060 Pocking, Germany, declare under our sole responsibility that devices in the HDC range of products, comply with Part 15 of the FCC Rules. Operation is subject to the following two conditions: (1) this device may not cause harmful interference, and (2) this device must accept any interference received, including interference that may cause undesired operation.

FEDERAL COMMUNICATIONS COMMISSION NOTICE

This equipment has been tested and found to comply with the limits for a Class A digital device, pursuant to Part 15 of the FCC Rules. These limits are designed to provide reasonable protection against harmful interference in a residential installation.

This equipment generates, uses, and can radiate radio frequency energy, and if not installed and used in accordance with the instructions, may cause harmful interference to radio

communications. However, there is no guarantee that interference will not occur in a particular installation. If this equipment does cause harmful interference to radio or television reception, which can be determined by turning the equipment off and on, the user is encouraged to try and correct the interference by one or more of the following measures:

- Reorient or relocate the receiving antenna.
- Increase the distance between the equipment and the receiver.
- Connect the equipment to an outlet on a circuit different from that to which the receiver is connected.
- Consult the dealer or an experienced radio/TV technician for help.

FCC Caution: Any changes or modifications not expressly approved by the party responsible for compliance could void the user's authority to operate this equipment.

This equipment has been designed to comply with the limits for a Class A digital device, pursuant to part 15 of the FCC Rules. These limits are designed to provide reasonable protection against harmful interference when the equipment is operated in a commercial environment.

FOR CUSTOMERS IN CANADA

This product has been tested for electrical safety and complies with:

CA /CSA C22.2 No.60065-03

DECLARATION OF CONFORMITY WITH CANADIAN ICES-003

This Class A digital apparatus complies with Canadian ICES-003.

Cet appareil numérique de la classe A est conforme à la norme NMB-003 du Canada.

Thanks and Unpacking

Thank you for choosing a NOVA HDC48 advanced system controller for your application. Please spare a little time to study the contents of this manual, so that you obtain the best possible performance from this unit.

All NOVA products are carefully engineered for world-class performance and reliability.

If you would like further information about this or any other NOVA product, please contact us. We look forward to helping you in the near future.

Unpacking the NOVA HDC48 series controller

After unpacking the unit please check carefully for damage. If damage is found, please notify the carrier concerned at once. You, the consignee, must instigate any claim. Please retain all packaging in case of future re-shipment.

INSTALLATION INSTRUCTIONS

- 1 THIS PRODUCT MUST BE EARTHED. Use only a flexible cable or cord provided with a green or green and yellow core which must be connected to the protective earthing terminal of a suitable mains plug or the earthing terminal of the installation. The cord must be of maximum length 7.5 meters, rated SJ, SJT, or SJE, 10A minimum and be marked VW-1.
- 2 Wiring to this product must only be made by suitably qualified personnel and must comply with all local requirements.
- 3 Do not install this equipment in an enclosed space. Do not limit free ventilation and movement of air around the back panel. Ensure that there is at least 100mm (4") of space around all sides of the product for ventilation.
- 4 Only use attachments and accessories approved by or specified by the manufacturer.

The User Guide

This user manual gives a progressively more detailed description of the functions of the NOVA HDC48 series advanced system controller. A single page quick reference guide is provided for those users who are experienced with this type of equipment and just need to know how to 'drive' the front panel. A detailed explanation of the front and rear panel controls and indicators is contained in the next section.

The final section describes each individual function or feature with annotated images explaining its use. Where appropriate, the graphical display is shown to further elaborate on the units operation.

To complete the manual a reference section is included, describing the technical performance of the device complete with graphs of filter responses.

Introduction and Key Features

Introduction

The NOVA HDC48 Advanced System Controller represents current state-of-the-art technology. Taking advantage of the latest advances in analogue to digital conversion and digital signal processing technologies the unit achieves performance levels higher than previous devices. Below is a list of key features, followed by some information on the major advancements of the HDC feature set.

Key Features

- NOVA minimal signal path design
- 96kHz sampling frequency provides for a nominally flat response beyond 40kHz.
- Three rotary encoders, illuminated buttons and graphical display provide a rapid, intuitive and user-friendly control interface
- High speed capable and flexible Ethernet communications that supports DHCP, static-IP and auto-IP and direct connection to a computer without the need for a router or a switch
- Class leading sonic performance achieved by the use of state of the art converters, a 4th Generation Analogue Devices Sharc DSP and highly advanced DSP algorithms
- Powerful Drive Module concept, abstraction from device centric to speaker based control
- Innovative Component Presets to allow individual outputs to be used for selected drivers of a loudspeaker system
- Twelve layers of Parameter Overlays for trouble-free Grouping
- Unique VX limiter providing dynamic control for passive 2-way enclosures
- Unique LIR linear phase crossover shapes giving FIR-like performance without the drawbacks
- Linear phase HF system EQ profiling which provides perfect integration between enclosures
- Innovative excursion control limiter with sliding High Pass Filter; limits only the damaging low frequencies
- Transducer thermal modelling provides regulation limiters, addressing long term overload
- Overshoot limiter governs amplitude of transient signals retaining average power whilst constraining peak energy
- Dante audio networking with automatic fallback to Analogue or AES3
- AES3 inputs and outputs, switchable in pairs
- High performance 'universal mains' switch mode power supply, designed in-house

Drive Modules

The HDC48 processor has a new way of ordering and grouping channels in order to give a more speaker-based approach to controlling, designing and recalling speaker configurations; these are called Drive Modules. A Drive Module is the Processing provided by one Input DSP Block, and a number of Output DSP Blocks, which are associated with one-another by means of routing. For example, if Input DSP Block B is routed to Outputs 3 and 4, then this is a 2-way Drive Module with Input DSP Block B forming the 'Master' control, and Output DSP Blocks 3 and 4 providing the driver-related control. Overall, this forms the processing typically for one loudspeaker sub-system. The System Engineer Drive Module control panel for this sub-system may then be used for control and monitoring of the associated speaker.

Drive Modules may be included in Module Groups, which use the Parameter Overlay feature in the HDC48 to achieve trouble-free Grouping in the System Engineer application.

The Presets in the HDC48 are Drive-Module centric, and are used to configure individual Drive Modules rather than the whole device.

Importantly, Drive Modules move the focus away from the processing device, and onto the loudspeaker systems.

A Drive Module Preset may be broken apart into Components, allowing any output to be used for any component within a Drive Module Preset (i.e. any driver in a loudspeaker subsystem).

See [Overview of Modules](#)

Overlays

When the HDC is used in Modules view in System Engineer, this allows the modules to be grouped into *Overlay Groups*. These groups allow various Input (master) parameters to be adjusted in *all modules* in that group, whilst maintaining independent parameter values across each group. This is achieved in the device by combining the parameters for all the layers for a given section (Gain Delay, EQ etc.). When an Overlay parameter is active, the Overlay indicator will become illuminated. The combined Gain or Delay etc. associated with a given section is shown on the module panel in System Engineer, within square brackets [] under the Delay and Gain for each input channel. The combined EQ curve is shown in an olive colour. The Input Mute button in System Engineer will flash if an overlay mute is active. On the device, the presence of an active overlay is generally indicated by square brackets “[]” after the parameter value on the display. An input overlay mute is indicated on the mute/clip indicator for that channel flashing. Note that overlay parameters cannot be adjusted on the HDC device itself; these can only be controlled by the System Engineer application. However, overlay parameters may be removed on the device – see [Overlay Flush](#). Note that overlays are not stored in presets or snapshots or carried in settings files.

LIR Linear Phase Crossover Filtering

The HDC also includes a new type of crossover filtering “Linear Impulse Response” (LIR) crossover filtering, which results in a Linear Phase crossover that has a constant delay regardless of frequency (unlike other types of crossover which delay different frequencies to a different extent, thus smearing the arrival time). The LIR crossover can thus be described as having a flat Group Delay response, and thus entirely free of Group Delay Distortion.

The shape of the LIR crossover filter is quite similar to a 4th order or 24dB/Oct Linkwitz-Riley filter, and maintains zero phase difference between the adjacent bands across the crossover region to keep the polar response rock steady.

FIR Linear Phase Equalisation

The Input High-Shelf Equalisers use Finite Impulse Response (FIR) filtering to produce Linear Phase equalisation; that is all frequencies are delayed by the same amount, perfectly preserving the transient response. This can also be important in applications where different amounts of EQ are applied to different parts of a speaker cluster, such as to add 'Throw' EQ boost so that parts of cluster which are throwing further can have HF absorption correction added. If this EQ is not linear phase, then the zones where the speakers combine may suffer frequency response anomalies.

Audio Connections

Input Connections

For each input channel there is a female XLR input connector. Even channel numbers are for Analogue inputs only. Odd channel numbers are either for Analogue inputs (when in Analogue input mode) or for AES3 input pairs (when in AES3 input mode).

The HOT, + or 'in phase' connection should be made to pin 2 of the XLR connector.

The COLD, - or 'out of phase' connection should be made to pin 3 of the XLR connector.

Pin 1 of the XLR connectors is internally connected to the chassis. The shield of the input cable should always be connected Pin 1 of the XLR to ensure that EMC performance and regulations are met.

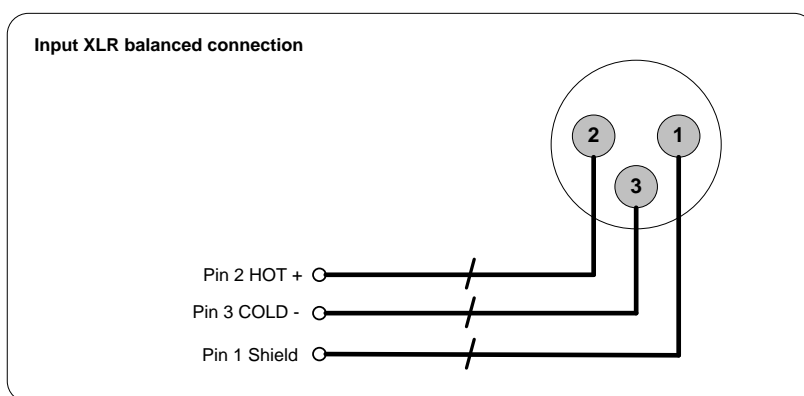

Output Connections

For each output channel there is a male XLR input connector. Even channel numbers are for Analogue outputs only. Odd channel numbers are either for Analogue outputs (when in Analogue output mode) or for AES3 output pairs (when in AES3 output mode).

The HOT, + or 'in phase' connection should be made to pin 2 of the XLR connector.

The COLD, - or 'out of phase' connection should be made to pin 3 of the XLR connector.

Pin 1 of the XLR connectors is internally connected to the chassis. The shield of the output cable should always be connected Pin 1 of the XLR to ensure that EMC performance and regulations are met.

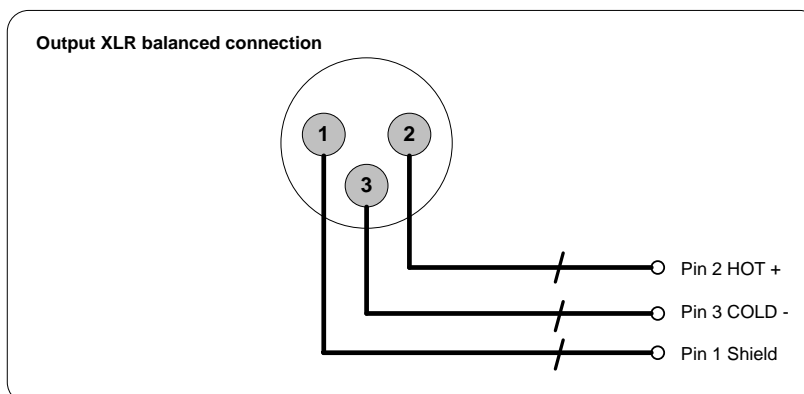

Using unbalanced connections

Please note that the use of unbalanced connections is not recommended, however, when connecting the device to an unbalanced audio source, the signal conductor should be connected to XLR pin 2. The 'Cold' conductor or cable screen should be connected to XLR pin 3 with a short connection made between pin 1 and pin 3.

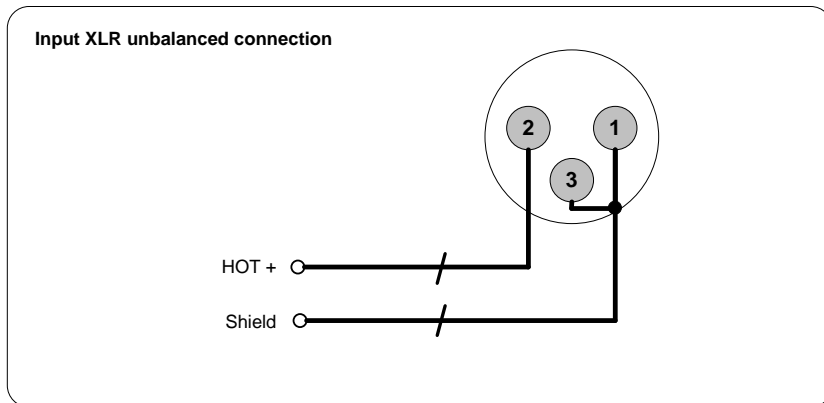

An unbalanced input may be driven by connecting pin-3 'cold' signal to the ground connection of the unbalanced destination input. The cable shield is connected to pin 1 at the source (this device), and to ground at the destination device (along with the pin 3 'cold' connection). Alternatively if the cable is a single core plus shield, the cable shield should be terminated to both pins 1 and 3.

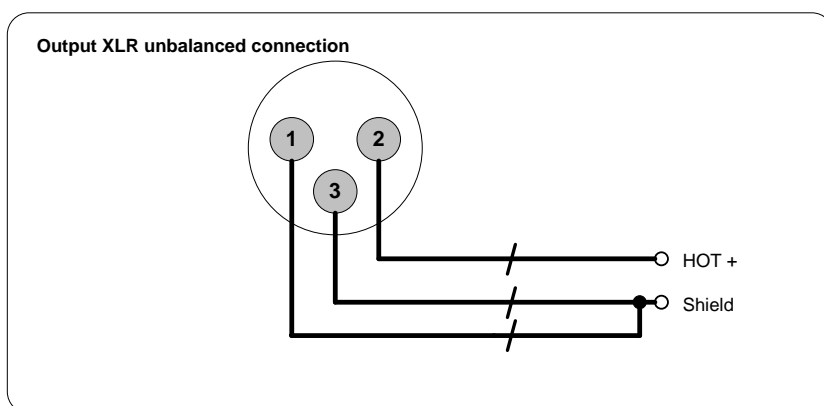

Panel Layouts

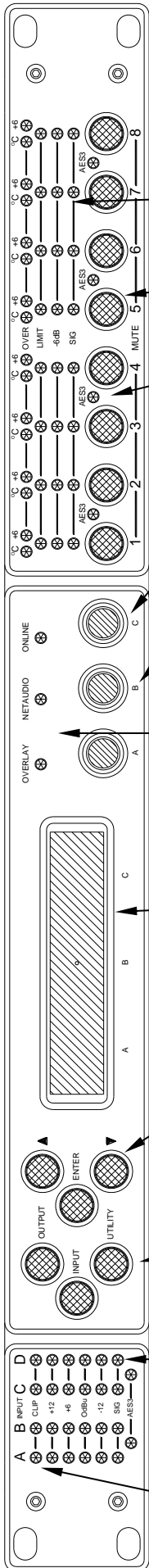

Limiter Indicators- The output indicators shows the status of the limiter and output level relative to the limiter threshold. The <SIG> indicator shows signal presence and will illuminate when a signal is present in the output. The second indicator <-6dB> shows that the signal has reached 6dB below the limiter threshold. The third <LIMIT> indicator indicates that the threshold of that output channel has been reached. The fourth <+6> indicates a signal 6dB higher than the limiter threshold. The <+6dB> indicator also refers to the excursion limiter and will illuminate when the threshold of the excursion limiter has been exceeded. The <°C> indicator shows that the thermal limiter is active, protecting against long term thermal stress. Please note that because of the long release time of the thermal limiter, the <°C> indicator may remain illuminated for several seconds after signal on that channel is reduced.

Mute Buttons- DSP output mute status is indicated and controlled by and illuminated button for each channel. These flash when the entire unit is muted from the AUX port or from System Engineer Mute-All.

AES3 Active Indicators- The “AES3” active indicators show when the AES3 input/output is active for that pair of channels. AES3 transmits two channels on one XLR cable. Channels 1 and 2 will be carried on connector 1; channels 3 and 4 will be carried on connector 3 and so on.

Parameter Encoders- Three velocity sensitive parameter encoders are used to adjust parameters shown on the display. Up to three parameters at a time are displayed on the screen. The parameter name is shown above the parameter value in each of the three screen sections.

Selection Indicators- Each page that is visited when navigating will usually show either one, two or three parameters labelled “A”, “B” and “C”, each of which can be edited by turning the Encoder associated with that parameter also labelled “A”, “B” and “C”.

Status Indicators- The “OVERLAY” indicator shows when there are parameters active on a group layer, which the user cannot access through the front panel of the device (see [Overlay Flush](#)). The “NETAUDIO” indicator shows that a networked digital audio card is installed and routed (Such as Dante™). The “ONLINE” indicator has three states: Off – the unit is offline and not connected to a computer or network. Flashing- the unit is searching for an IP address; if the unit does not find an IP address the unit will assign itself an IP address automatically and the indicator will stop flashing. On- the unit is online and connected with software. IP settings can be viewed or changed within the <UTILITY> pages.

Graphical Display- When the device is switched on, it will show the Home screen. This provides a useful overview of channel allocation and Drive Module presets. The screen contrast can be changed by pressing the <UTILITY> button to navigate to “Screen” and using encoder “A” will change the percentage; this can also optimise the viewing angle. In most pages the currently selected channel and parameter information is displayed on the upper part of the screen and the parameter value on the lower part of the screen.

Page Selection Buttons- When one of the buttons <INPUT>, <OUTPUT> or <UTILITY> is illuminated, the up <▲> and down <▼> arrows will also illuminate, informing the user that these buttons may be used to scroll through the various pages of parameters that may be viewed and edited. The <ENTER> button is used to confirm an operation such as storing or recalling a preset or snapshot. It will illuminate when the user is being invited to press it. It will flash when warning the user that pressing this button will activate an important function.

Menu Buttons- There are three buttons to determine which section of the device to view or edit. The <OUTPUT> button displays pages of parameters associated with a particular output channel. The <INPUT> button displays pages of parameters associated with a particular input socket or input DSP channel. Pressing <INPUT> or <OUTPUT> buttons repeatedly will scroll through the inputs/outputs of the processor. After the last channel, navigation returns to the Home screen. The <UTILITY> button displays pages of miscellaneous parameters not associated with any particular channel. Whilst in Edit mode, one of these three buttons will be illuminated. They are mutually exclusive – pressing one of the buttons will deselect any others that are active. Pressing Utils will escape back to the Home screen.

Input Signal Indicators- A set of five indicators show “Sig”, “-12”, “OdBu”, “+6” and “+12” for each of the DSP inputs “A” “B” “C” “D”. The signal present Indicators operate at approximately -40 dBu, giving a useful indication of even relatively low input signal levels. The “OdBu” indicators are intended to show nominal operating level and can also be useful for setting system gain structure.

Input Clip/mute Indicators - warn the user of input overload and operate at 1dB before clip. The “CLIP” Indicator will only come on when all other signal lights are illuminated. This indicator also shows a muted input state, and will remain illuminated at all times whilst mute is active. Input mute is turned on/off in the <INPUT> gain page. This indicator will also flash regularly if a Module Group has muted this channel.

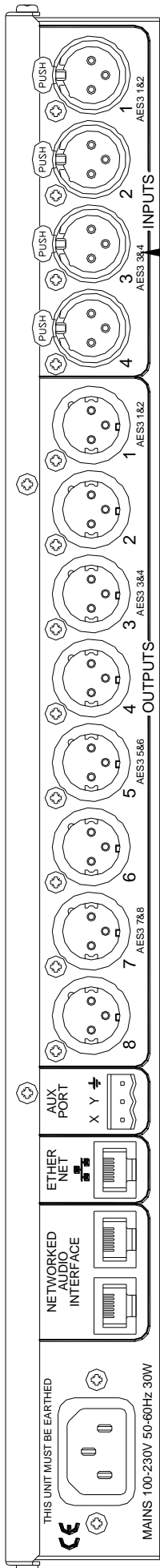

Audio Input Connectors- All audio connections are fully balanced and wired: pin-1 to ground (as required by the AES48 standard), pin-2 hot & pin-3 cold. When AES3 operation is selected on an input pair, the Odd channel connector is used for both channels (e.g. Input 1 is used for channels 1 and 2).

Audio Output Connectors- The processed outputs are impedance balanced, and wired: pin-1 directly bonded to ground (as required by the AES48 standard), pin-2 hot and pin-3 cold. When AES3 operation is selected on an output pair, the Odd channel connector is used for both channels (e.g. Input 1 is used for channels 1 and 2).

Auxiliary Port- The auxiliary port may be configured to recall snapshots or apply muting.

Ethernet Communications Port- The device may be controlled entirely from another controller, typically a Personal Computer, running an application that is compliant with the ObCom standard such as System Engineer. Connection will normally be made to the controller via this Ethernet port connector. This port is also used for updating the firmware in the unit.

Networked Audio Ports- The HDC48 has the option for networked audio ports; if none are required a blanking plate will be fitted. There are several options for networked audio including Dante™. For a full list please consult your vendor.

Power Inlet- The Linea Research HDC48 unit should be connected to a suitable mains electricity supply using an earthed IEC C14 connection power lead. The processor has a switch mode power supply that is capable of operating with a nominal mains voltage of 85V to 240V, 50/60Hz without re-configuration.

NOTE: The HDC48 must be earthed to a suitable power earth; failure to do so may affect performance and/or operation and will invalidate warranty and could be potentially hazardous.

Operation

Starting up the unit

The unit will power up as soon as power is applied to the IEC power inlet; there is no power switch. When power is present the unit will go through its start-up cycle - first all the indicators will illuminate then go off, while the screen displays the boot loader information. Next the screen will display the application firmware information, and all the mute buttons will illuminate. The display will then show the Home screen indicating drive module configurations; the mutes will then return to the state they were in when the unit was powered off.

Overview of Modules, Presets Components and Snapshots

A **Drive Module** represents a loudspeaker subsystem (e.g. Sub and Composite), and comprises one input channel and a number of output channels, associated with one-another by routing. The size of the Drive module is determined by the number of outputs in it. The device may contain up to four Modules.

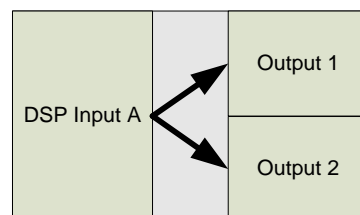

A **Module Preset** is a collection of settings (parameters) for a Drive Module of a particular size. The Preset contains a set of parameters for one input and a set of parameters for each of the outputs in the module. When a Module Preset is recalled, it will automatically change the routing between Input DSPs and Outputs, consuming a number of outputs according to the size of the Drive Module. Recalling a Module Preset thus always creates a Drive Module with consecutive outputs.

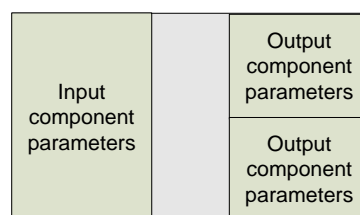

A **Component** is a collection of settings (parameters) for one (input or output) channel. Any one of the output components in a Module Preset may be recalled to any individual output.

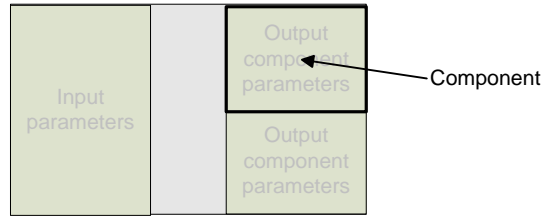

These concepts are depicted in the System Engineer application as in the following example of a 2-way Module:

input				output			
DSP	input	name	module preset recall	out	source	name	component recall
A	1	Left	49 DF1815	1	DSP A	Sub	49.1 DF1815.Sub
				2	DSP A	Composit	49.2 DF1815.HighMid

A **Snapshot** is a device-wide representation of most of the settings in the device. This is represented as four Input Component numbers, eight Output Component numbers, plus a number of machine-centric settings such as routing and Input/Output Analogue/Digital selection etc.

Device Settings	Input A component number	Output 1 component number
		Output 2 component number
	Input B component number	Output 3 component number
		Output 4 component number
	Input C component number	Output 5 component number
		Output 6 component number
	Input D component number	Output 7 component number
		Output 8 component number

Drive Modules

The HDC48 uses Drive Modules to represent loudspeaker sub-systems. Drive modules result in a less processor-centric and more speaker-orientated system design. A drive module is defined as the processing provided by one Input DSP, and a number of outputs, which are associated with one-another by means of routing. For example, if Input DSP B is routed to outputs 3 and 4, then this is a 2-way Drive Module; input DSP B forming the 'master' control, and output DSP 3 and 4 providing the driver-related control. The Input DSP parameters then control the Drive Module (and thus the speaker sub-system). The Drive Module control panel in the System Engineer application is then used for control and monitoring of this sub-system.

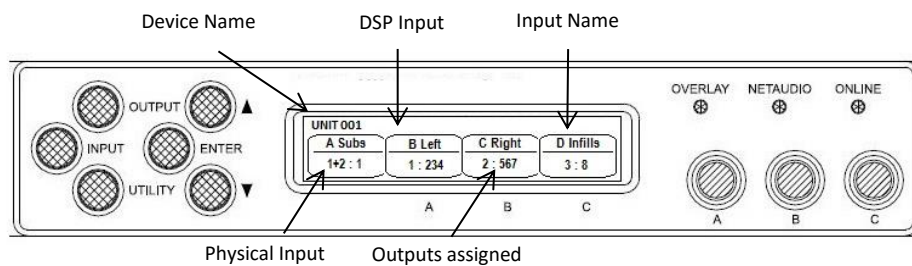

Drive Module Presets

Presets do *not* change the settings device-wide. Rather, recalling a Module Preset creates a Drive Module by 'consuming' a number of consecutive outputs and setting up routing between the Input the preset was recalled on and those outputs. The parameters in that Drive Module are then set according to the parameters in the components in the Module Preset.

Note however, that modules with non-consecutive outputs can be created by manually manipulating the routing, and then recalling [Component Presets](#) to the individual outputs. The resulting system can then be stored in a [Snapshot](#). Such a Module cannot be saved in a Module Preset.

Note: DSP inputs are not the same as physical inputs. The HDC48 has four audio inputs and four DSP inputs. This is a matrix mixing system where any physical inputs, be they analogue, AES3 or networked audio feeds, can drive any number of DSP inputs.

Component Presets

A Component Preset represents the processing for just one output. Any part of a Module Preset may be recalled to any one output. A Drive Module comprised of parameters which have been recalled to its outputs using Component Preset Recalls can then be saved into another [Module Preset](#) provided the outputs remain consecutive (i.e. you have not changed the routing manually). If the routing has been changed manually, then the whole arrangement may be saved into a [Snapshot](#). Also see [Snapshots](#) and [Recalling Components](#).

Navigation and Designing Crossovers

The HDC48 has 50 Drive Module preset locations and these can be stored and recalled from the <INPUT> pages, for the channel being viewed. To design a new crossover, press the desired <INPUT> or <OUTPUT> button to enter the pages where the parameters for each of the channels are shown. Once in these pages the up <▲> and down <▼> buttons will scroll through the processing parameters for the selected input/output. Pressing the <INPUT> or <OUTPUT> button repeatedly will scroll through the channels. This allows the user to enter all the parameters for each of the channels in the signal chain or enter each parameter for each channel one after another. A parameter may be adjusted when it is displayed by turning one of the three parameter encoders “A”, “B” or “C”.

Each of the three parameter encoders is associated with a zone on the display. Adjusting the leftmost parameter encoder “A” will change the value of the parameter showing in the leftmost zone of the display above the “A” and so on. Turning an encoder clockwise will increase the value of a parameter, or anticlockwise will decrease it. The encoders are velocity-sensitive so turning an encoder rapidly will cause the action to ‘accelerate’, so the value changes more rapidly.

Note that the presence of an active overlay on one of these parameters is indicated by “[]” being appended to the displayed parameter value – e.g. “+2.6dB[]”. See [Overlays](#).

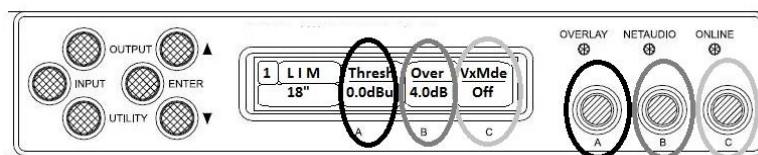

Factory Module Presets

The device may contain a library of *Factory Presets* designed to suit a range of enclosures.

Factory Presets may contain some parameters that are fixed and hidden from view; the remainder of the parameters are available for user manipulation. The number and type of hidden parameters is dependent on the Factory Preset, typically crossover frequencies, output delay and some EQs are hidden; those settings that are a function of the loudspeaker cabinet design and should not require adjustment for different applications. *Factory Presets* are locked (as indicated by a ‘box’ symbol after the Preset name) so they cannot be over-written. The user can, however, store an edited version of a Factory Preset in any free preset location.

In addition to the *Factory Presets* the device may have further ‘*Skeleton Presets*’ which will help to create new presets. They can be used to develop settings for any loudspeaker combination and are recalled in the same way as the *Factory Presets* described above. These Presets are also usually locked but the user can name and store their own edited versions in any free preset location.

Storing Module Presets

Once a drive module has been created it can be stored by pressing the <INPUT> button until the edited channel is reached, then pressing the down <▼> button until **store** page is reached. Using encoder “A” will change the preset number. When the destination preset is reached, pressing the <ENTER> button will enable the name associated with that preset to be changed. Once the name changing is active, the character to be changed will be highlighted and encoder “A” will edit the character. Using encoder “B” will move through the character positions. Once the new preset name has been assembled, the operation can be confirmed by pressing the <ENTER> button, then a message will be displayed, “Enter to confirm or ▼ to exit”; pressing <ENTER> will store the preset.

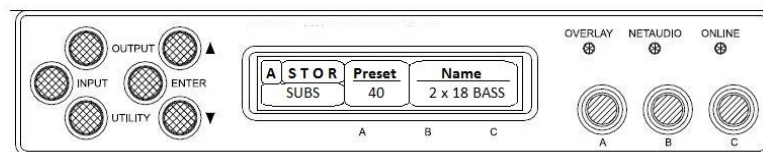

Note: Storing a Drive Module preset for a module which is not configured with consecutive outputs is not permitted.

Note: When storing a Drive Module preset on the device, Component Names cannot be edited. To change Component names, the Module Preset must be saved in the System Engineer application.

Recalling Module Presets

To recall a Drive Module preset, press the <INPUT> button, then use the down <▼> button navigate to the RECL Preset page. Using the encoder, “A” will scroll through the presets available. When the desired preset is reached, pressing <ENTER> will display the message “Enter to confirm or ▼ to exit”, pressing <ENTER> will recall the preset. Note that presets do not contain and do not disturb parameter Overlays. See [Overlays](#)

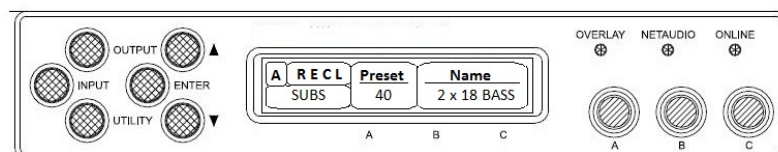

Recalling Components

To recall a Component Preset (to a single output), press the <OUTPUT> button, then use the down <▼> button navigate to the RECL Preset page. Using the encoder, “A” will scroll through the component presets available (as indicated by the ModulePreset.Component number and ModulePreset.Component name). When the desired component is reached, pressing <ENTER> will flash the Enter button. Pressing <ENTER> again will then recall the component preset. Note that component presets do not contain and do not disturb parameter Overlays. See [Overlays](#)

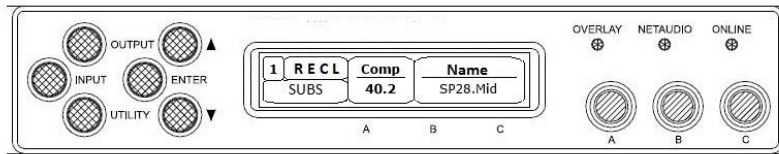

Also see [Snapshots](#).

Input

AES3 / Network Inputs

In addition to the usual analogue inputs, the HDC can also accept AES3 digital inputs. The same physical XLR sockets are used for both Analogue and AES3 inputs; the function of these being determined by the Type parameters in the Input Type menu. The Input sockets 1 and 3 are used to input pairs of AES3 channels, so setting the input to 'AES3' on either Input 1 or Input 2 will cause the other channel to change also. Similarly, adjusting the setting of Input 3 will affect Input 4 and vice-versa. When an input socket is selected for AES3 operation, the "AES3" indicator under the input meters will illuminate.

There is no 'standard' for the relative gains between Analogue, Dante and AES3 so it may be necessary to adjust the digital input gains to normalise them. So that the relative gain between an Analogue input and an AES3 input can be normalised, it is possible to adjust the gain of the AES3 channel using the Input Route AES3 Gain parameter. For example, to achieve $0\text{dBFS} = +18\text{dBu}$, set the digital trim to -2dB . To achieve $0\text{dBFS} = +24\text{dBu}$, set the digital trim to $+4\text{dB}$.

This device will automatically select the correct sample rate from the incoming stream between 28kHz and 108kHz.

When the Digital Audio Network option (e.g. Dante) is fitted, it is also possible to select any channel(s) as being sourced from this network. To do this, connect the audio network connection to the connection on the rear of the HDC, and set the relevant Input Type menu Type parameter to "Dante" (for example.)

When the Digital Audio Network input is installed and routed, the "Net Audio" indicator above the encoders will illuminate. This indicator will come on even if there are no cables plugged into the networked audio port on the HDC.

Again, it is possible to set the relative gain between an Analogue input and the Digital Audio Network (Dante) using the Input Trim Dante gain parameter.

This device will automatically select the correct sample rate from the incoming stream.

For other details on the operation of the Digital Audio Network, please refer to the relevant manufacturer's documentation.

Automatic Input Selection (Fallover)

When a Digital Audio Network input is installed, it is possible to configure the input selection to be automated. The Input TYPE screen has a Fallover parameter, which defaults to Manual, allowing you to select what Type of input you wish to use. When Fallover Dante>AES3 is selected, then the Dante source will be automatically selected if it has a valid audio stream on it. If the Dante stream should fail, then AES3 is automatically selected instead. Note that automatic selection will take precedence over manual selection, so if you try to manually select Dante when there is no valid Dante stream, then it will revert to AES3. Similarly, if Dante>Analogue is selected, then Dante will be selected unless the stream fails, in which case AES3 will be used.

Gain and Polarity

The gain page of the input channel selected allows users to increase or decrease the amount of signal going into the selected input. Using encoder “A” will change the value in 0.2dB steps from -40dB to +20dB. The presence of an active Group Overlay parameter is indicated by the ‘[]’ symbol (See [Overlays](#)). This page will also allow users to change the polarity of the selected input from normal to reverse, using encoder “B”. Using encoder “C” will mute the selected channel.

Delay

The delay page which controls the amount of delay associated with the input channel selected and is adjustable from 0 to 998ms. The delay parameter is adjustable in fine steps at low values; the adjustment becomes progressively coarser as the value increases. The presence of an active Group Overlay parameter is indicated by the ‘[]’ symbol. See [Overlays](#).

High Pass Filter

System high pass filtering is provided for the input signal. Filter type is selectable from 1st order, Butterworth, Bessel, Linkwitz-Riley and Hardman. Filter slopes of up to 4th order or 24dB / octave are provided. Not all filter types are available in all slopes. For example 18dB / octave Linkwitz-Riley filters do not exist.

The Hardman type filter is always described by its order as the filter becomes progressively steeper rather than following a linear slope so a dB/octave description is not accurate.

Parametric Equalisation

There are nine stages of equalisation available for each input channel, three shelving filters and six parametric filters.

FIR Shelving EQ

The Input High Shelf EQ is implemented using a Finite Impulse Response (FIR) filter, and exhibits a linear phase response; that is all frequencies are delayed by the same amount. This can be important in applications where different amounts of EQ are applied to different parts of a speaker cluster, such as to add 'Throw' EQ boost so that parts of cluster which are throwing further can have HF absorption correction added. If this EQ is not linear phase, then the zones where the speakers combine may suffer frequency response anomalies.

Being a linear phase FIR equaliser, this necessarily introduces some latency delay, which is constant regardless of the settings. However, when the 'Enable' parameter is set to “Off”, it is removed from the signal path entirely, so it does not add any latency. Using encoder “A” will change the frequency

parameter from 2kHz to 20kHz, using encoder “B” will enable/disable the filter, and using encoder “C” will change the cut or boost in 0.2dB increments. The presence of an active Group Overlay parameter is indicated by the ‘[]’ symbol being appended to the Gain value (See [Overlays](#)). The filter (and its associated latency) can be completely removed by setting the enable parameter to the “Off” position. Note that this EQ can only be used in Module Groups if set to ‘On’.

Also see [Latency Delay](#).

Parametric Filters

Parametric filters are defined by frequency, bandwidth and gain. The frequency is controlled by encoder “A” and ranges from 10Hz to 25.6kHz. The bandwidth, shown as Width on the screen, is controlled by encoder “B” and ranges from 0.10 octaves to 5.2 octaves. Bandwidth can be shown and adjusted as Q or Octaves (Oct). Gain is controlled by encoder “C” and is adjusted in 0.2dB increments. The presence of an active Group Overlay parameter is indicated by the ‘[]’ symbol being appended to the Gain value. See [Overlays](#).

Also see [Bandwidth Units](#) in Utilities.

Routing

Routing allows users to route any physical analogue or digital signal channel to any DSP input. This is effectively a matrix mixing system where all DSPs can be driven from any one input, or from pairs of inputs “1+2”, “3+4”, “1+3”, “1+4”, “2+3” or “2+4”. Summed inputs have 6dB of attenuation so that a sum of largely similar programme material remains at the correct calibrated level.

Output

AES3 outputs

In addition to the usual analogue outputs, the HDC also allows outputs to be sent digitally using AES3. The same physical XLR sockets are used for both Analogue and AES3 outputs; the function of these being determined by the XLR parameters in the Output Route menu. The Odd numbered output sockets are used to output pairs of AES3 channels. When an output socket is selected for AES3 operation, the “AES3” indicator under the output bar graphs will illuminate.

The output sample rate for AES3 will always be 96kHz. The calibration between analogue and AES3 levels is 0dBFS (AES3) = +20dBu (Analogue).

Gain and Polarity

The gain page of the output channel allows users to increase or decrease the relative signal gain for the selected output. Using encoder “A” will change the value in 0.2dB steps from -40dB to +20dB. This page will also allow users to change the polarity of the selected output from normal to reverse, using encoder “B”.

Delay

The delay page controls the amount of delay associated with the output channel selected and is adjustable from 0 to 998ms. The delay parameter is adjustable in fine steps at low values; the adjustment becomes progressively coarser as the value increases.

High and Low pass Filters

High pass and Low pass crossover filtering is provided for the output signal. Filter type is selectable from 1st order, Butterworth, Bessel, Linkwitz-Riley, Hardman and LIR Linear Phase using encoder “B”. Filter slopes of up to 8th order or 48dB / octave are provided. Not all filter types are available in all slopes. For example 18dB / octave Linkwitz-Riley filters cannot be selected because they do not exist.

The Hardman type filter is always described by its order as the filter becomes progressively steeper rather than following a linear slope so a dB/octave description is not accurate.

LIR Crossover Filtering

Unique to NOVA, “Linear Impulse Response” (LIR) crossover filtering gives a Linear Phase crossover which has a constant delay regardless of frequency (unlike other types of crossover which delay different frequencies to a different extent, thus smearing the arrival time). The LIR crossover can thus be described as having a flat Group Delay response, and thus entirely free of Group Delay Distortion, this is exactly the same as can be provided by common FIR filtering but without the complications and disadvantages inherent with the FIR technique.

The shape of the LIR crossover filter is similar to a 4th order Linkwitz-Riley filter, and maintains zero phase difference between the adjacent bands across the crossover region to keep the polar response rock steady.

Note that very narrow bandwidths are not possible with this crossover type. If the Low Pass frequency is too close to the High Pass frequency, then the filter will ‘mute’.

Linear Phase filtering necessarily introduces delay; the laws of physics demand it. To keep this delay to a minimum, it is recommended that more conventional crossover shapes (such as Linkwitz-Riley) are used for the very lowest frequency high-pass edge, particularly if this is less than perhaps 100Hz, which is well below the frequency thought to cause audible ‘Group Delay Distortion’.

This constant delay will depend on the lowest high-pass frequency used in the crossover filters in a given Drive Module.

Also see the section on [Latency Delays](#).

Parametric Equalisation and All-Pass Filters

There are ten different EQ filters; two shelving filters and eight parametric filters. Parametric filters are defined by frequency, bandwidth and gain. The frequency is controlled by encoder “A” and ranges from 10Hz to 25.6kHz. The bandwidth, shown as Width on the screen, is controlled by encoder “B” and ranges from 0.10 octaves to 5.2 octaves. Bandwidth can be shown and adjusted as Q or Octaves (Oct). Gain is controlled by encoder “C” and is available in 0.2dB increments.

Any of the six Parametric filters can be used as All-Pass filters. When a filter is set to All-Pass mode, the Gain parameter value will show as “AllPass” on the display. This setting may only be engaged or disengaged from the System Engineer PC application.

Also see [Bandwidth Units](#) in Utilities.

Limiters

The HDC48 includes three limiters in the output signal path. Please note that whilst the Limiters in this product offer protection for amplifiers and drivers, they can never protect from all possible scenarios, therefore NOVA is not responsible for any damage which might occur.

VX Limiter (Unique to NOVA)

This is a peak-detecting signal limiter. The VX Mode parameter determines the style of limiter. When Virtual Crossover (VX) mode is off, the limiter is controlled in a conventional manner; the only controls being Threshold and Overshoot.

The Overshoot limiter prevents the signal from exceeding threshold during the attack phase of the main limiter by more than a predetermined amount. The optimal Overshoot setting is usually about 8dB. Lower Overshoot settings will sound progressively 'harder'.

When VX mode is engaged, the user can choose the crossover point of a 'virtual crossover', which incorporates two limiters per output so the user can individually limit the drivers in a passive 2-way enclosure using individual thresholds, and optimised attack and release characteristics for each. The Threshold of the second 'Hi' limiter is set relative to the threshold of the first 'Lo' limiter.

The effect of the VX threshold and split frequency on the Limiter curve can be seen in System Engineer.

This Limiter introduces some delay. In non-VX mode, this delay will depend on the lowest high-pass frequency used in the crossover filters in a given Drive Module. In VX mode, the delay is related to the Split frequency. This delay will be applied to all of the outputs in a given Drive Module to keep them in phase.

Also see [Latency Delays](#)

Tmax Thermal Limiter

The Thermal Limiter is intended to protect the driver against damage due to over-heating. It models the temperature of the driver, and constrains the output signal level in order to keep the average output power below a predetermined limit, applying attack and release characteristics to go some way towards modelling the complex thermal circuit of a driver's voice coil and magnet assembly.

Three parameters are available for adjustment:

Threshold – the continuous RMS voltage which the driver should be able to withstand. This is calibrated at the output of the amplifier. The Thermal Limiter can be defeated by setting the Threshold to the maximum "Off" value.

Attack – The time-constant of the speed at which the driver heats up (in seconds).

Release – The time-constant of the speed at which the driver cools down (expressed as a multiple of the Attack time).

Also see [Amplifier Gain](#)

Xmax Excursion Limiter

The Excursion Limiter protects the driver against excessive linear movement of the cone and voice-coil which could otherwise cause mechanical damage. Since this movement (excursion) is largely

related to the inverse of the signal frequency, drivers are prone to being damaged by very low frequencies. This limiter is progressively more sensitive at lower frequencies and, rather than varying the gain to provide the limiting action, it uses a sliding high-pass filter to progressively curtail the low-frequency response, effectively limiting the linear excursion to below the X-max specification of the driver.

To set the limiter up, it is necessary to know the shape of the family of Excursion vs. Frequency curves of the driver for various drive voltage levels. A curve should then be chosen where the slope is high where it passes through the specified X-Max value for the driver. The peak voltage and frequency of this point should then be noted.

The Xmax limiter is usually then set up using just two parameters:

Threshold – the peak voltage of the point arrived at above. This is calibrated at the output of the amplifier. The Excursion Limiter can be defeated by setting Threshold to the maximum “Off” value.

Frequency – The frequency at which the above threshold voltage is appropriate.

A further parameter “*Min*” may also be available for more advanced applications. This allows the increasing limiting action at lower frequencies to level-off below a certain frequency. In most application, this would be left set to its default value of 5Hz.

Amplifier Gain

Expressed in dB, this is the gain of the amplifier which the output of the HDC48 is feeding. This value must be entered to allow the HDC to correctly calibrate the thermal and excursion limiter for the amplifier in use.

Routing

Outputs can be driven from any DSP input. This routing is the fundamental means by which Drive Modules are created. Routing should always consume outputs consecutively alphabetically and numerically. However, non-consecutive Drive Modules may be created using manual routing and [Recalling Components](#). See the [drive module](#) section of this user manual for more information.

AES3

AES3 outputs are switched in pairs from System Engineer or front panel. The limiter calibration for AES3 outputs is 0dBFS = +20dBu.

Utility Pages

Screen Contrast

The Screen page in the “**UTILITY**” section adjusts the contrast (and optimal viewing angle) of the screen from 0-100% in 1% increments using encoder “**A**”.

Stereo Linking

Stereo linking is available between DSP Drive Modules A & B and between C & D. Changing a parameter in either of the stereo linked Drive Modules will change the other linked Drive Module. Stereo linking is controlled by the **STEREO** page in the “**UTILITY**” menu.

Note: Stereo linking will only work when the linked Drive Modules are of equal size.

Note: Stereo Linking state is not stored in Presets (but is stored in Snapshots)

Current Ethernet IP Address

This may be viewed in the “IP Curr” page of the “UTILITY” menu. This value cannot be edited.

IP Mode

The Ethernet IP address may be automatic “Auto” or may be a fixed static value “Static” as determined by the “IP Mode” page of the “UTILITY” menu.

WARNING – Do NOT use Static mode unless your IT system specifically requires it. Auto mode should always be used where possible since in this mode, the HDC can always be ‘discovered’ by the System Engineer application. When in Static mode, the IP Address will flash on the Home screen.

Also see [Ethernet Configurations](#).

IP Static

This allows the Static Ethernet IP address to be adjusted by the three rotary encoders on the IP Static page of the “UTILITY” menu. This page will only be visible when in Static mode.

Store Snapshot

This page of the “UTILITY” menu allows a Snapshot of the device to be stored.

Also see [Snapshots](#).

Recall Snapshot

This page of the “UTILITY” menu allows a Snapshot to be recalled.

Also see [Snapshots](#) and [Aux Port](#).

Bandwidth Units

This page of the “UTILITY” menu allows the Bandwidth of Parametric Equalisers to be viewed and adjusted in either Octaves or ‘Q’.

Aux Style

This page of the “UTILITY” menu allows the action of the Aux port to be viewed and adjusted.

Also see [Aux Port](#).

Ethernet

Ethernet configurations

IP addressing in the Device can be completely automatic; No setup is required.

When first installing and launching System Engineer, the computer Firewall may ask to allow System Engineer to access the network. **NOTE: This must be allowed.**

DHCP

There are two primary IP address ranges – one used when there is a DHCP server, and another (‘Link Local’) where there is no DHCP server (so the Device and the Computer will instead use ‘Auto IP’ to allocate themselves an IP address). Both the device and the computer must be in the same IP

address range. In a local network environment such as an office where there is a DHCP server, both the computer and the Device will be in the DHCP IP address range, and so will connect immediately.

AUTO-IP

The device will initially search for a DHCP server when first switched on (during which time its Online Indicator will be flashing). As it can take up to one minute to establish that there is no DHCP server available, this is the time it may take before Auto IP is entered.

Please be aware that it can also take some time from a computer being switched on in an isolated network (without a DHCP server), or unplugged from a network with DHCP to time out of DHCP searching, so it will not connect immediately to amplifiers that are already using Auto IP. The time it takes before it decides to revert to Auto IP depends on the operating system but it can take several minutes to acquire an Auto IP address.

Static-IP

If the device or the computer has a static IP address set, System Engineer may not be able to 'see' the device if it is in a different IP Address range (i.e. in a different *subnet*). ***Unless there are good reasons it is best to avoid the use of static IP addressing if at all possible.***

IP Troubleshooting

If System Engineer cannot connect to the device:

- A Router acting as a DHCP server is highly recommended as this provides the most trouble-free way of administering IP addresses. Always switch on any DHCP server before connecting either the computer or HDC to the network.
- If not using a DHCP server, check that the Current IP address in the device is compatible with the IP address of the computer. Generally, the leftmost two sets of 3 digits should be the same.
- If there is no Router in the system acting as a DHCP server, wait 10 minutes (for the computer to acquire the correct IP address) and try again.
- Check that the Firewall in the computer will allow System Engineer access to the network ***for both private and public networks***. Please refer to the Help feature in the System Engineer application for further guidance on this

Snapshots

A Snapshot may be recalled either via the device User Interface, from the System Engineer application or via the AUX port on the rear of the HDC48.

The snapshot menu is accessed via the utility pages. Recalling a Snapshot triggers the recalling of a Component to each input and output, and may change other device-wide settings, effectively recalling a processor-wide preset. In addition to being able to recall snapshots from System Engineer and from the HDC's front panel, some of the snapshots are also recallable from the auxiliary port.

Also see [Aux Port](#)

The parameters inside the Drive Modules are not individually stored in Snapshots. Recalling a Snapshot will merely trigger the recall of the appropriate Input and Output Components, rather than restoring the parameters that were active when the Snapshot was stored. This has the distinct advantage that the library of OEM presets may be updated without having to be concerned about

what parameters might have been saved in users Snapshots. It does however require that any existing edits to the parameters in Drive Modules are stored into Drive Module presets before a Snapshot is stored.

Also see [Overview Of Modules Components and Snapshots](#)

AUX Port

The AUX has two inputs, X & Y. These allow simple contact closure devices (relays or switches) or external logic signals to change the state of the amplifier as described below. Connecting an AUX input to ground (the earth symbol) will trigger it; there is no requirement for an external voltage. However, the ports can also be triggered directly by a logic signal as long as the logic 'low' goes below +0.5V. *Do not connect systems if their logic 'high' voltage exceeds +24V.*

The AUX port may be configured to work in a number of ways by adjusting the Style parameter in the Aux page of the [Utility menu](#):

- **None** - No operation
- **2+Mute** (Event or State) – Either Snapshot 1 or Snapshot 2 may be recalled by applying a *momentary* or *static* connection to an Aux port terminal, or the device may be muted by Grounding both Aux port terminals
- **3 Snaps** (Event or State) – Either Snapshot 1 or 2 or 3 may be recalled by applying a *momentary* or *static* connection pattern to an Aux port terminals
- **4 Snaps** (State) – One of the four Snapshots 1,2,3,4 may be selected by applying a *static* connection pattern to the Aux port terminals
- **3+Mute** (State) - One of the three Snapshots 1,2,3 may be selected by applying a *static* connection pattern to the Aux port terminals, or the device may be mute by Grounding both Aux port terminals

The following table shows the action taken for various Aux connection patterns in the various Aux port modes:

AUX X	AUX Y	2+Mute ACTION (State or Event)	3 Snaps ACTION (State or Event)	4 Snaps ACTION (State)	3+Mute ACTION (State)
Open	Open	No Change	No Change	Recall Snapshot 1	Recall Snapshot 1
Gnd	Open	Recall Snapshot 1	Recall Snapshot 1	Recall Snapshot 2	Recall Snapshot 2
Open	Gnd	Recall Snapshot 2	Recall Snapshot 2	Recall Snapshot 3	Recall Snapshot 3
Gnd	Gnd	Mute	Recall Snapshot 3	Recall Snapshot 4	Mute

Some of the above modes allow the AUX Port to be used either in *Event* mode (whereby a momentary push-button or momentary relay contact closure on one of the AUX lines will cause a Snapshot to be recalled). Or in *State* mode (where a rotary switch etc. connected to both of the AUX lines selects which Snapshot to use).

Some of the other modes only allow *State* mode, requiring the connection pattern to persist in order for the Snapshot to be held as the current one.

NOTE: That if the contact closure port is being driven, or if the Aux Style is set to one of the *State* modes, this will override the snapshot recall setting in the menu (or in System Engineer). Also

under these conditions, the snapshot menu items are not accessible, and the Home screen will show the Snapshot number as a reminder.

Also see [Snapshots](#).

Latency delay

All Digital Signal Processing, and conversion between different formats of signal – analogue/digital/network etc, necessarily introduce some delay (latency) to the signal path. Of course, we strive to minimise these latencies. Small as they are, it is sometimes useful to know their precise values. The following describes the principal latencies introduced by various parts of the HDC48 product:

Input/Output Latencies

	Analogue Input	0.385ms
OR	Digital input at 96KHz sample rate	0.5ms
OR	Digital input at 48KHz sample rate	0.66ms
	Analogue Output	0.402ms
OR	AES3 Output	0.1ms
OR	Dante Output	0.5ms (TBC)

Processing Latencies (limited to a minimum of 1.53ms):

	Input HiShelf FIR	0.48ms (0ms if set to 'Off')
	LIR Linear Phase crossover	1.19ms/Fhp(kHz), limited to 30ms maximum **
	VxLim Limiter (VX mode off)	0.12ms/Fhp(kHz), limited to 1.53ms maximum **
OR	VxLim Limiter (VX mode on)	0.358ms/Fsplit(kHz), limited to 1.53ms max ††

** This latency figure is calculated using the crossover High-pass frequency (in kHz)

†† This latency figure is calculated using the Vx Split frequency (in kHz)

Important tip: The processing latency is constant at 1.53ms unless LIR crossover filters or FIR HiShelf EQs are used, so normally you would just need to add the Input and Output delays to this constant value.

If LIR or FIR are in use, the Processing latency of a Drive Module may increase beyond this figure. The Drive Module Latency may be viewed on the Latency page of the relevant Input DSP channel. This can be accessed by pressing Input then down until the latency page is reached.

When LIR, is used the Vx Limiter can take the overall latency above the 1.53ms. When high pass frequency is set below 40Hz the filter will automatically revert to Linkwitz riley, this is set so that the latency will not exceed 30ms as stated.

Note that the latency reported on the Latency screen in the utilities menu does not include the Input/Output latencies.

When using input FIR filters, LIR or VX Limiters always check the view latency screen to see the latency attributed to that Drive Module.

Example:

Input/Output

Analogue Input	0.385ms
Analogue Output	0.402ms

Processing

Input HiShelf FIR (Off)	0ms
LIR Linear Phase crossover (500Hz)	2.38ms
VxLim Lim (VX mode on, 1KHz Fsplit)	0.358ms
Total	3.525ms

Note that the latencies within a Drive Module are equalised among outputs of that Drive Module. That is, padding delay will be automatically added to some outputs such that the total latency is the same in each output of a Drive Module.

This latency equalisation does not extend outside a Drive Module, so Drive Modules are not guaranteed to have the same latency as one-another.

Secure Mode

When activated, this will disable all the front panel controls so they cannot affect the signal path, making the unit secure against tampering. The only option that is left for user control is snapshot recall. If this is not required then storing the same device state in every snapshot will effectively disable this feature. When in secure mode, the indicators still operate normally. To activate secure mode, press and hold the utility button for 5 seconds. To deactivate, press and hold the utility button for 5 seconds. When in secure mode, this will be shown on the display. Note that the Ethernet communications port is still active in secure mode.

Overlay Flush

If the device has been used in Module Groups, and still has an active Overlay (as indicated by the Overlay indicator), these can be removed by simultaneously pressing and holding for 5 seconds the Utility and Enter buttons. See [Overlays](#).

Revert to Factory Settings

If you wish to erase all of your settings in the device and revert everything to factory settings, then simultaneously press and hold for 5 seconds the Up button and the Mute 1 button, then follow the prompts on the display. Only continue by pressing the Enter button if you are sure this is what you want to do. Otherwise, press the Down button to escape. Alternatively, you can access this feature from System Engineer application using the 'Hamburger' button on the bottom-right of the device control panel, selecting 'revert to factory settings'.

Processing Block Diagram

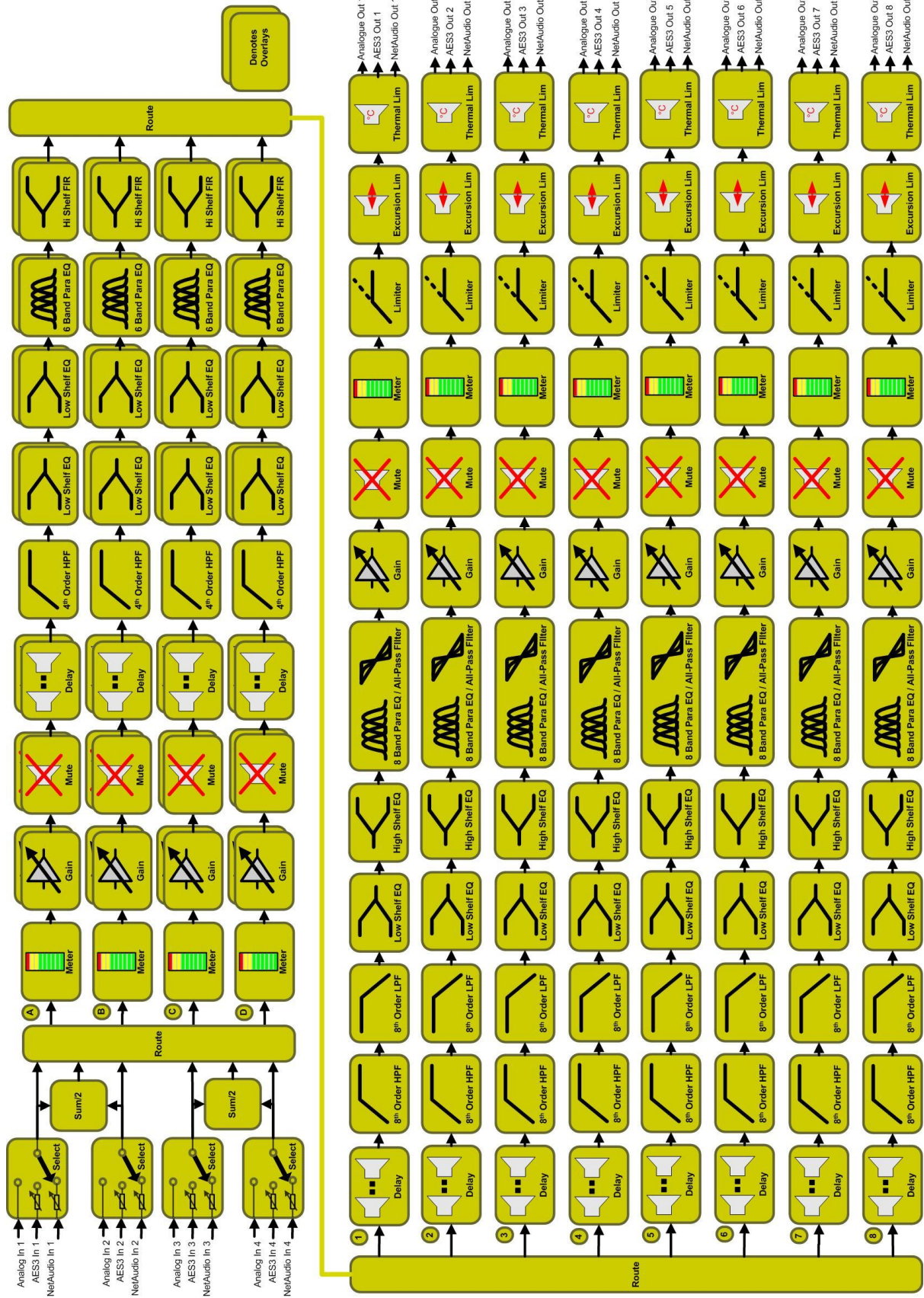

Input Menu Map

Utility Menu Map

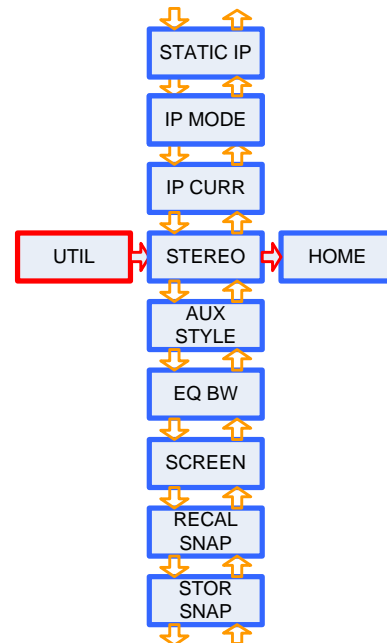
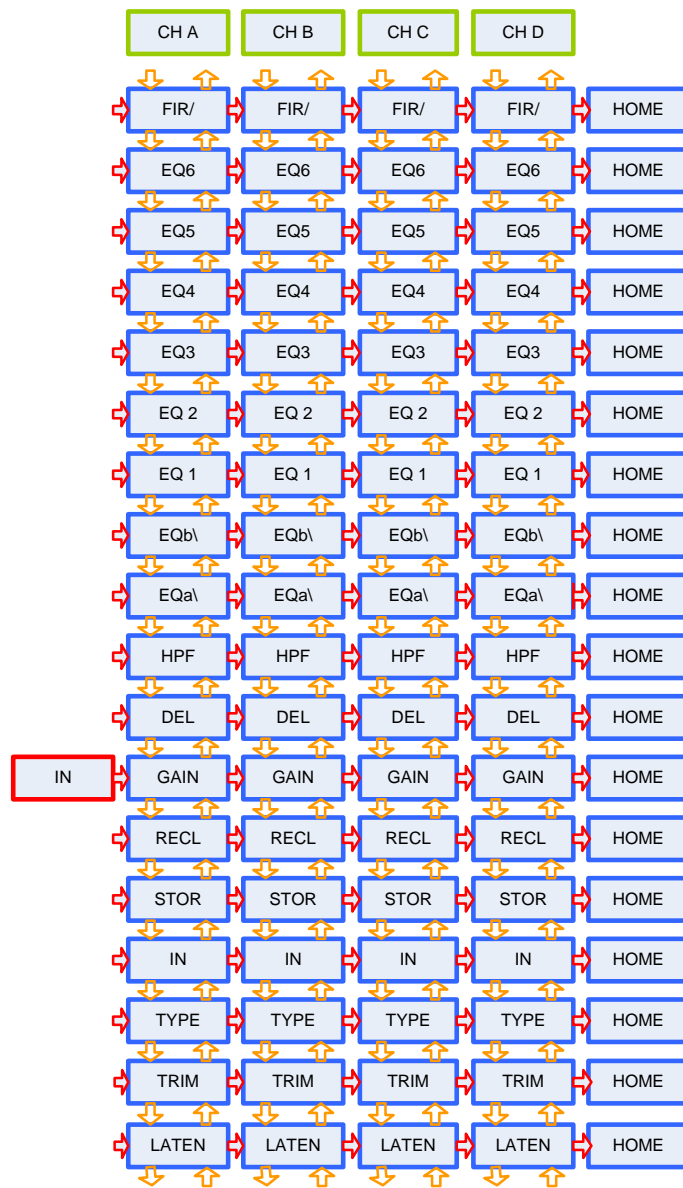

KEY

- MENU PAGE
- MENU BUTTON
- CHANNEL NO.

- UP/DOWN BUTTON PRESS
- MENU BUTTON PRESS

Output Menu Map



EQ and Filter Response Graphs

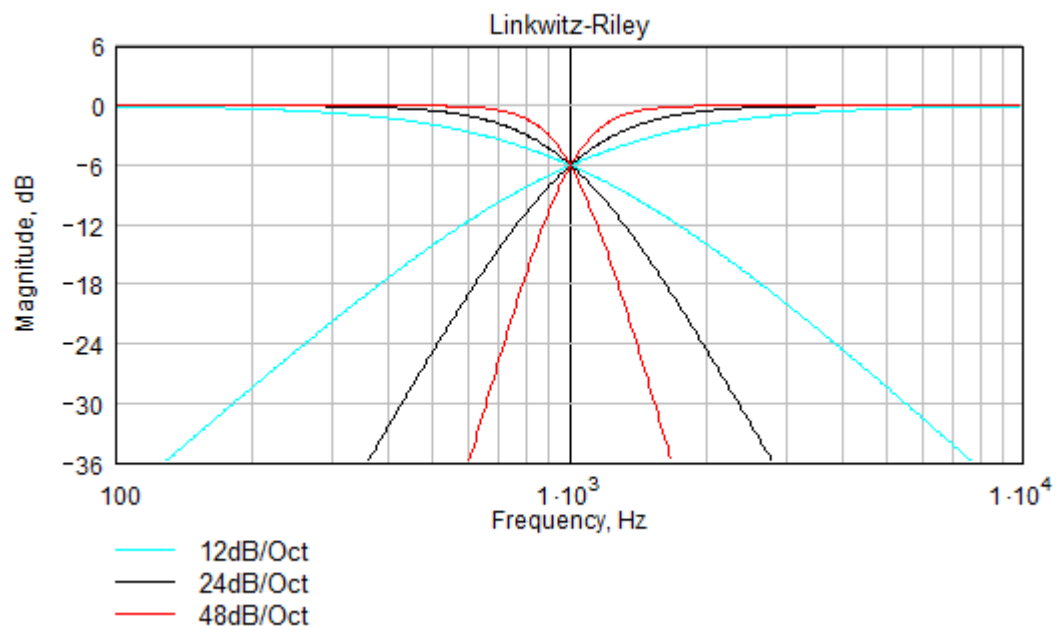
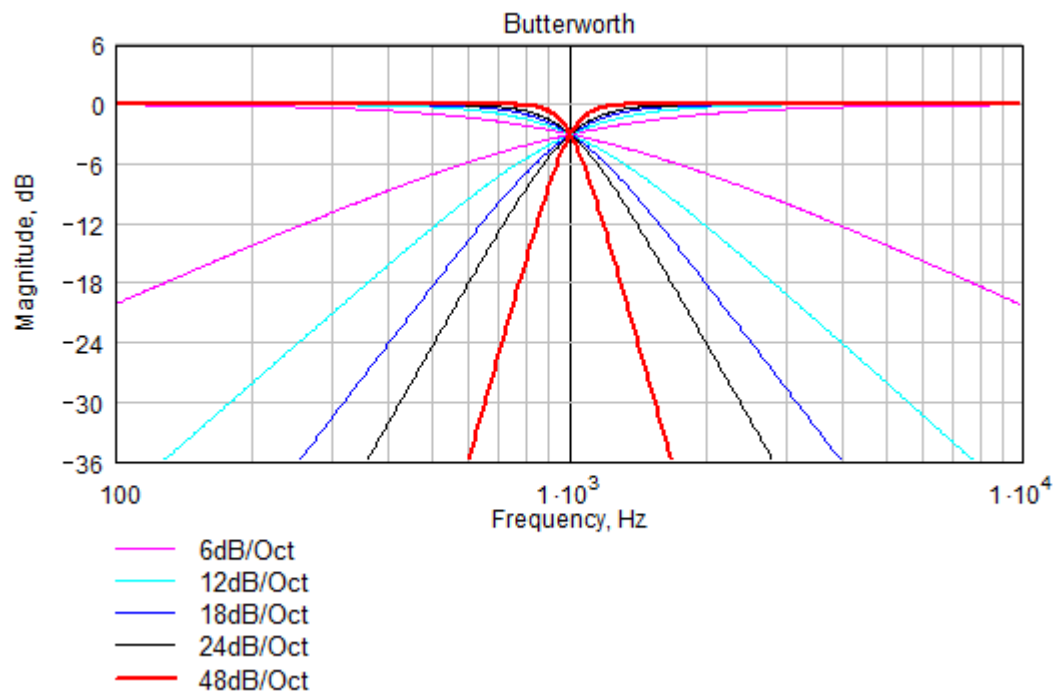

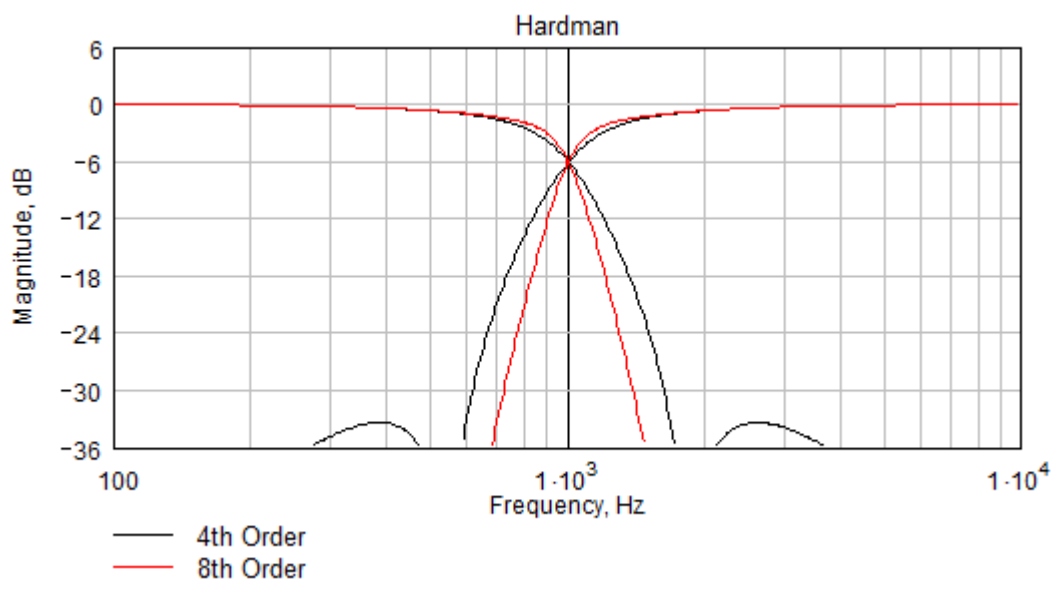
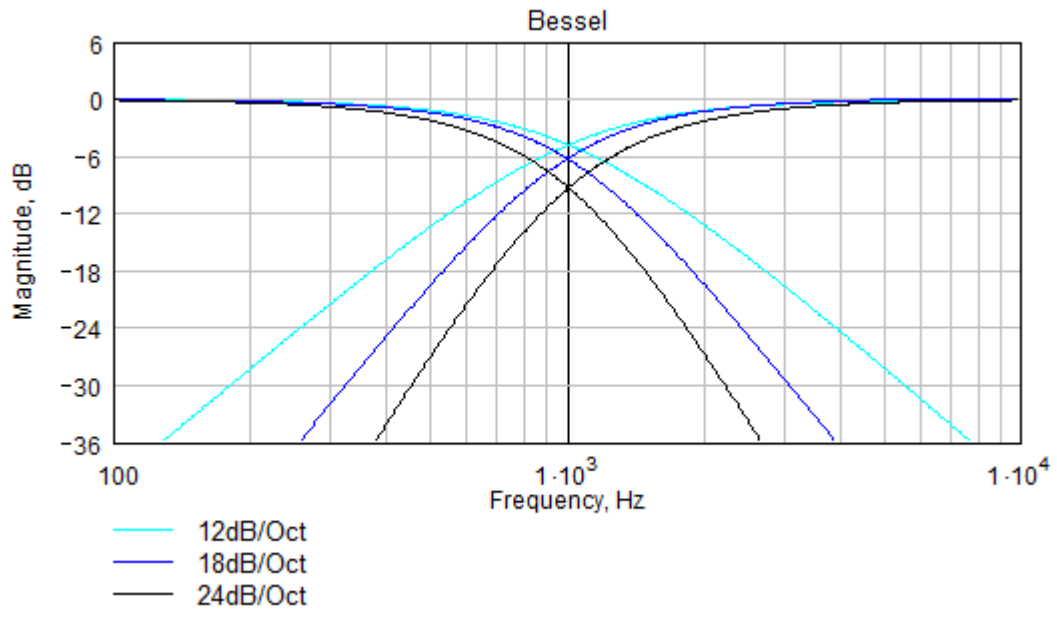

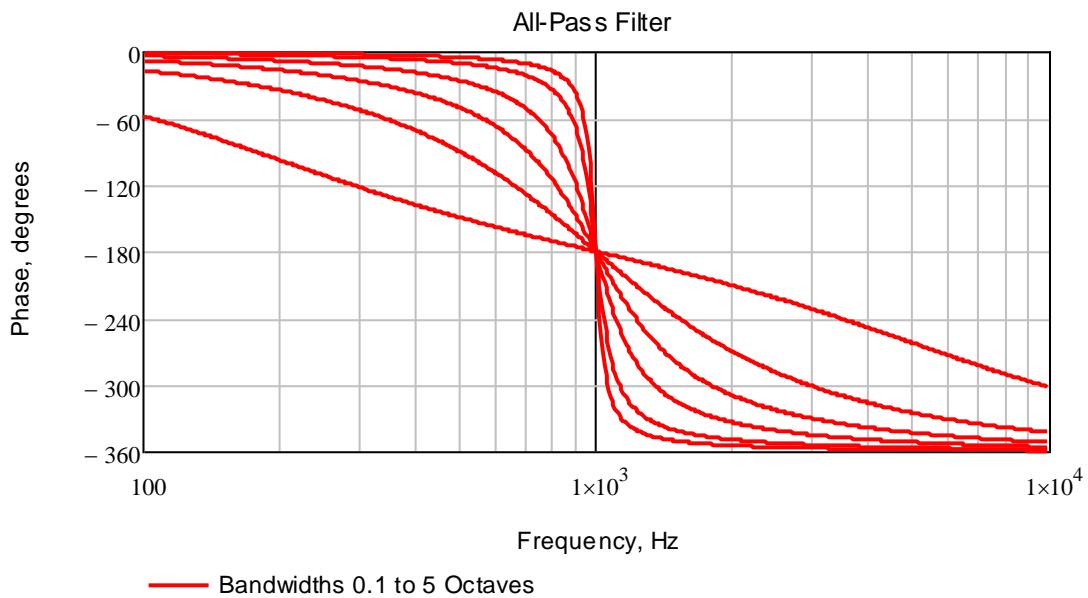
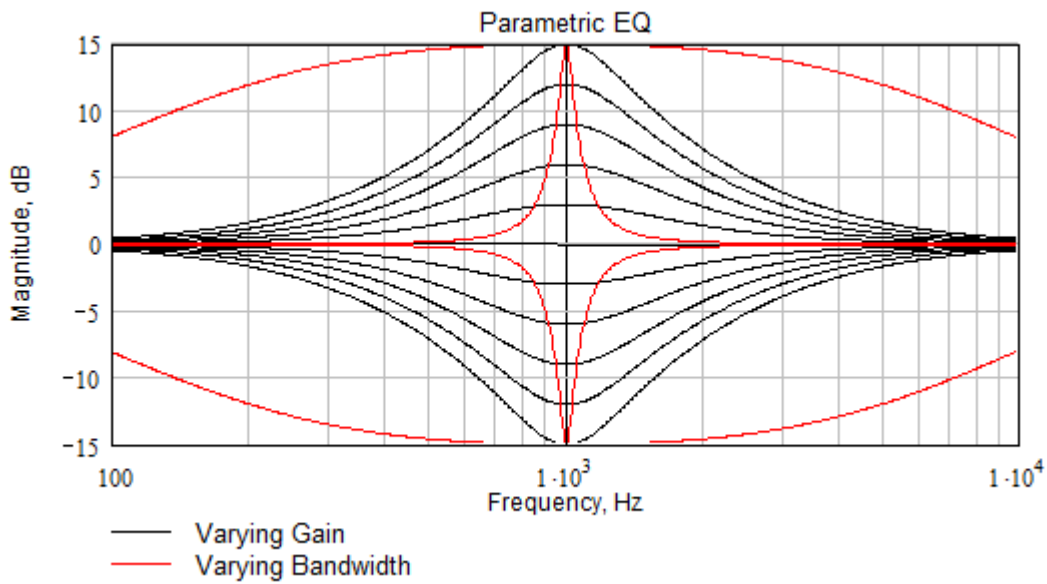
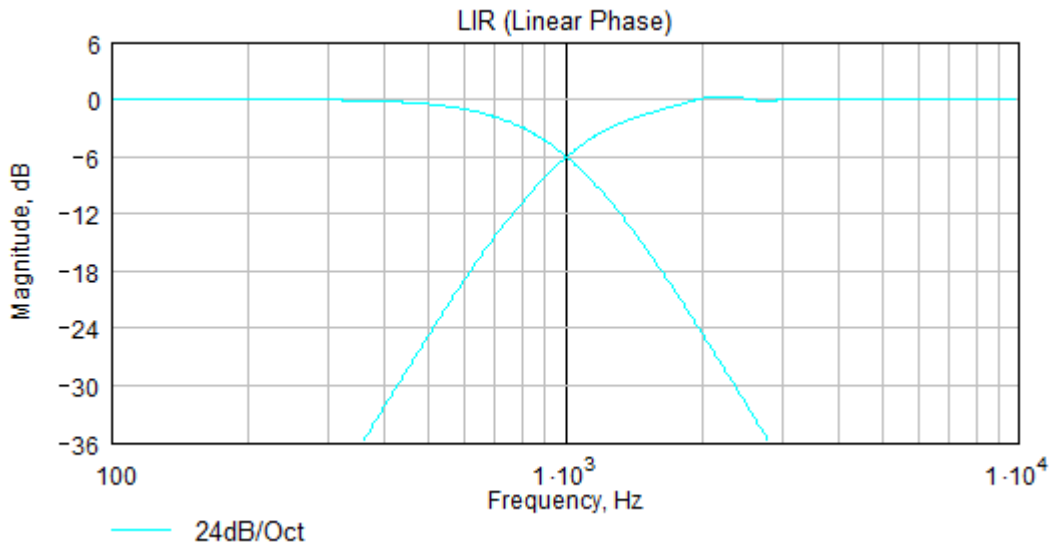

Technical Specifications

Input impedance: >10k Ohm balanced

Output Imp: <100R imp. balanced

Max Input level: +20dBu

Max Output level: +18dBu into 600R

Sample rate: 96kHz

AES3 Input sample rate: 28kHz – 108kHz

AES3 Output sample rate: 96kHz

Frequency Response: 10Hz - 40kHz

Input Dynamic range: >120dBa Typ.

Output Dynamic range: >118dBa Typ.

THD (20Hz–20kHz) : <0.008% Typ.

Mains required 85-230VAC 50-60Hz

Mains power: 30W

Connectors

Audio input: 3 pin female XLR

Audio output: 3 pin male XLR

Ethernet: Shielded RJ45

Aux Contact: Phoenix Connector

Mains: 3 pin IEC

Environmental

Temperature: 0 to +45°C

Humidity: 0 to 80% RH (non-condensing)

Dimensions

Height: 1U (44mm)

Width: 482mm

Depth: 254mm

Weight: 2.7kg net

Options

There is internal provision for digital audio network option cards to be factory fitted. Currently NOVA support Dante from Audinate.

